

ITEM No.	DRAWING No.	DESCRIPTION	QTY.
1	F051 2906 03	3050L SHEETED SHEDDING HURDLE	3
2	F051 2905 19	1930L RADIUS 1000H 3R SHT GATE IN FRAME	1
3	F051 2901 18	1870L RADIUS SHEETED HURDLE	3
4	F051 2900 30	3050L 4 RAIL SHEETED SHEEP HURDLE	5
5	F051 2820 10	76 O/D H/POST C/W B/PLATEPIVOT & LUGS	1
6	F051 2818 06	CLAMP ON SHEEP LUG T/S 40X40 SHS	2
7	F051 2813 08	570mm WIDE RACE JOINER GALV	1
8	F051 2812 03	570W X 730L 2WAY DRAFTING STOP GATE	1
9	F051 2810 14	LIFT & SWING GUILLOTINE GATE ASSEMBLY	1
10	F051 2807 25	2555L 6R SWING AND SLIDE GATE	1
11	F051 2804 27	1750L ANYHAND DUAL RAILED GATE IN FRAME	3
12	F051 2804 25	2500L PAIR 6 RAIL GATES IN FRAME	1
13	F051 2802 30	3050L SLIDING GATE HURDLE	1
14	F051 2802 25	2500L SLIDING GATE HURDLE	4
15	F051 2800 30	3048MM 6 RAIL SHEEP HURDLE GALV	4
16	F051 2018 03	915L 16DIA COUPLING BAR	34
17	F051 2017 30	3080L X 1030W STAND IN FOOTBATH	1

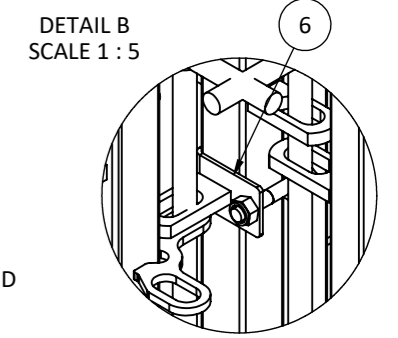
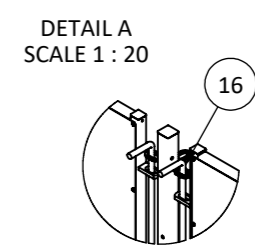
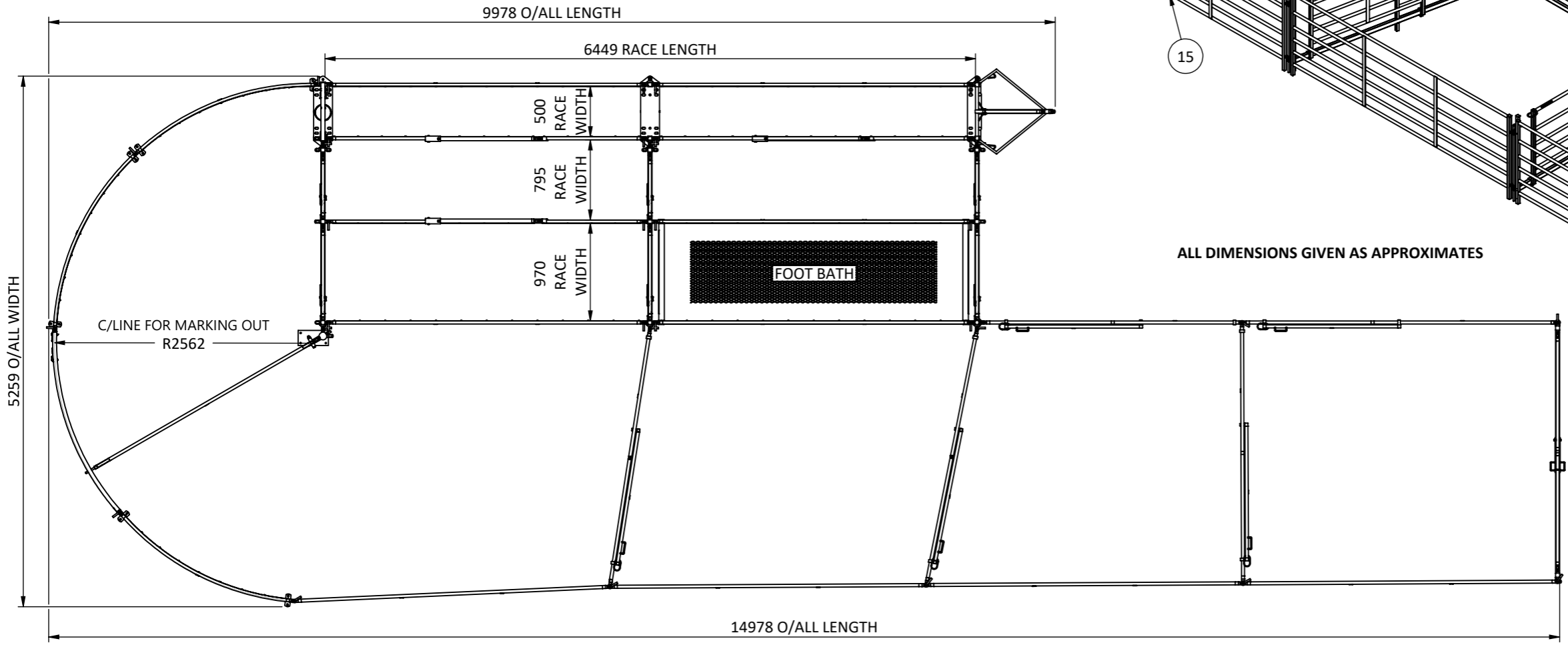
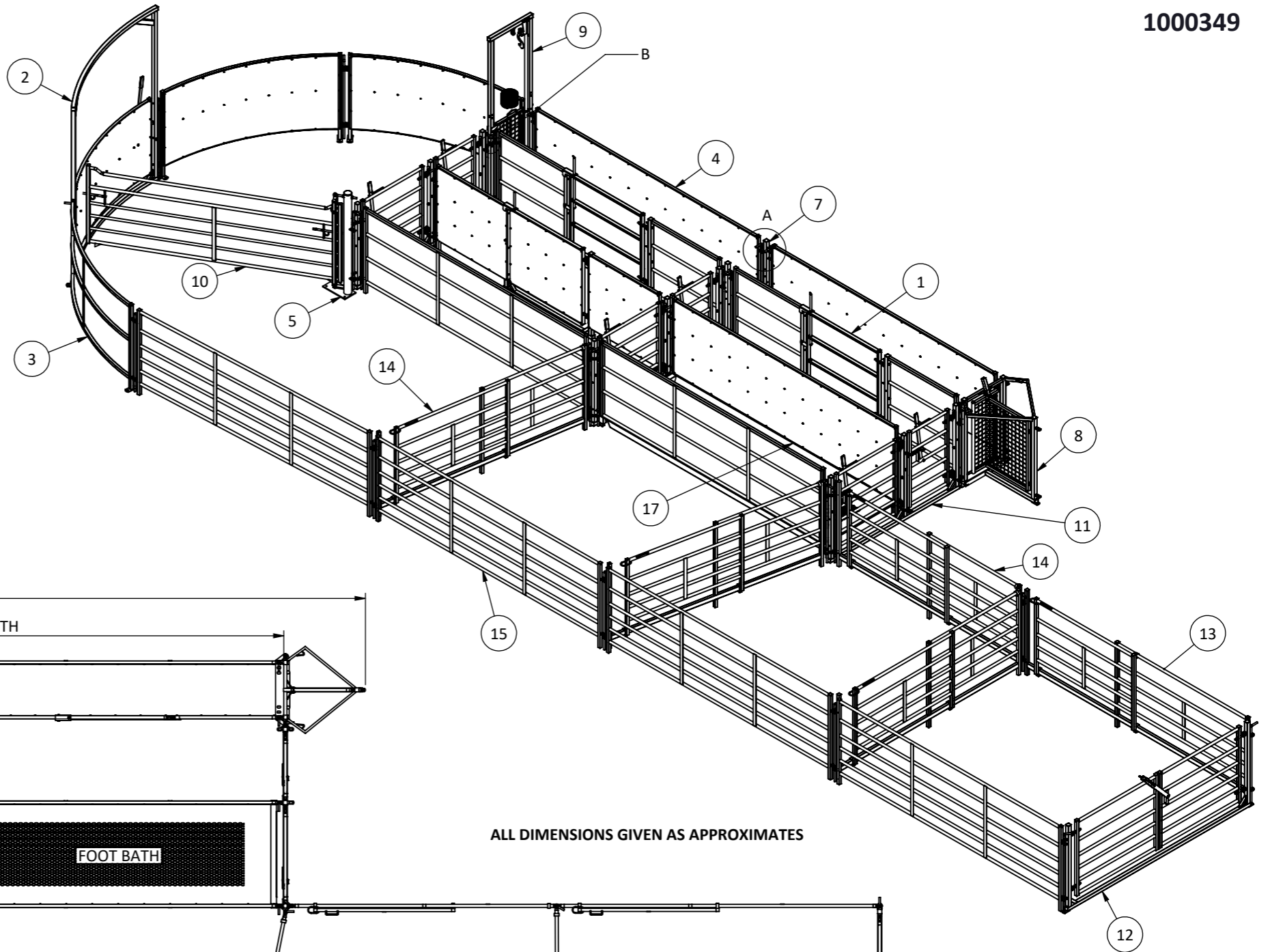

COUPLING RODS TO BE USED FOR FIXING TO ADJACENT HURDLES/POSTS ETC

2 No. CLAMP ON SHEEP LUGS REQUIRE FITTING TO GUILLOTINE GATE

TITLE SHEEP HANDLING SYSTEM D PLUS

PART No. 1000349 **Rev.** A

Tel:01782 339320
Fax:01782 339322
www.iae.co.uk
email.sales@iae.co.uk

THE INFORMATION CONTAINED IN THIS DRAWING IS THE PROPERTY OF "IAE". COPYRIGHT IS RESERVED BY THEM AND THE CONTENT USED ON THE CONDITION THAT IT IS NOT COPIED, REPRODUCED, RETAINED OR DISCLOSED TO ANY UNAUTHORISED PERSON EITHER WHOLLY OR IN PART WITHOUT THE CONSENT IN WRITING OF "IAE"

GENERAL NOTES		GENERAL TOLERANCES (UNLESS OTHERWISE STATED)	
1.REMOVE ALL BURRS & SHARP EDGES		BOUGHT IN	
2.ALL THREADS TO BE ISO METRIC COARSE		MADE IN HOUSE	
3.ALL HOLES ON CTR (UNLESS OTHERWISE STATED)		0 - 100 +/- 0.25	
WELDING NOTES		100 - 500 +/- 0.5	
1.FULLY WELD (UNLESS OTHERWISE STATED)		500+ +/- 1	
2.ALL WELDS TO BE FREE OF SPIKES & SPATTER		ANGULAR +/- 0.5°	
ALL DIMENSIONS ARE IN MILLIMETRES			
MATERIAL	MILD STEEL	A3	SCALE 1:50 DO NOT SCALE
FINISH	HOT DIP GALV	DRAWN JE	DATE 15/11/2019
EST.NATURAL WEIGHT(kg.)	1057.60	SHEET 1 OF 1	IF IN DOUBT - ASK!

REV	DESCRIPTION	ECR	INT	DATE
A	FIRST ISSUE	N/A	JE	15/11/2019